

## Small Engine Range - Specifications

2, 3 or 4 cylinders with high inertia flywheel for smooth running at low rpm.

Heater plugs for cold starting below 5°C, fuel filter, **MECHANICAL** fuel lift pump, **MECHANICAL** fuel injection pump and **MECHANICAL** engine governing ensures steadfast performance regardless of ambient conditions.

**QUIET GEAR DRIVEN CAMSHAFT** for maximum engine reliability and reduced servicing, as no timing chains or toothed belts have to be replaced.

Subject to criteria, Kubota based engines accommodate installation angles up to 15° maximum when static and 25° when heeling.

The Beta 10, 14, 16, 20 & 25 are equipped with a standard 40 Amp alternator, the Beta 30, 35, 38 & 45T are equipped with a standard 70 Amp alternator all are driven by a polyvee belt/pulley and achieve full power at cruising speed. **OPTIONAL OR ADDITIONAL ALTERNATORS** & polyvee belt/pulley drive transmission are available.

Optional special feet service, to ease planning and installation Beta Marine offer 3D computer aided modeling for the design & the manufacture of bespoke feet to allow direct installation on to your vessels existing engine bearers.

Mechanical & hydraulic, in-line, down angle or V drive gearbox options. Output rotation is clockwise in ahead, viewed from the gearbox end.

Cutaway Images Are For Illustration Purposes & Not Necessarily Representative

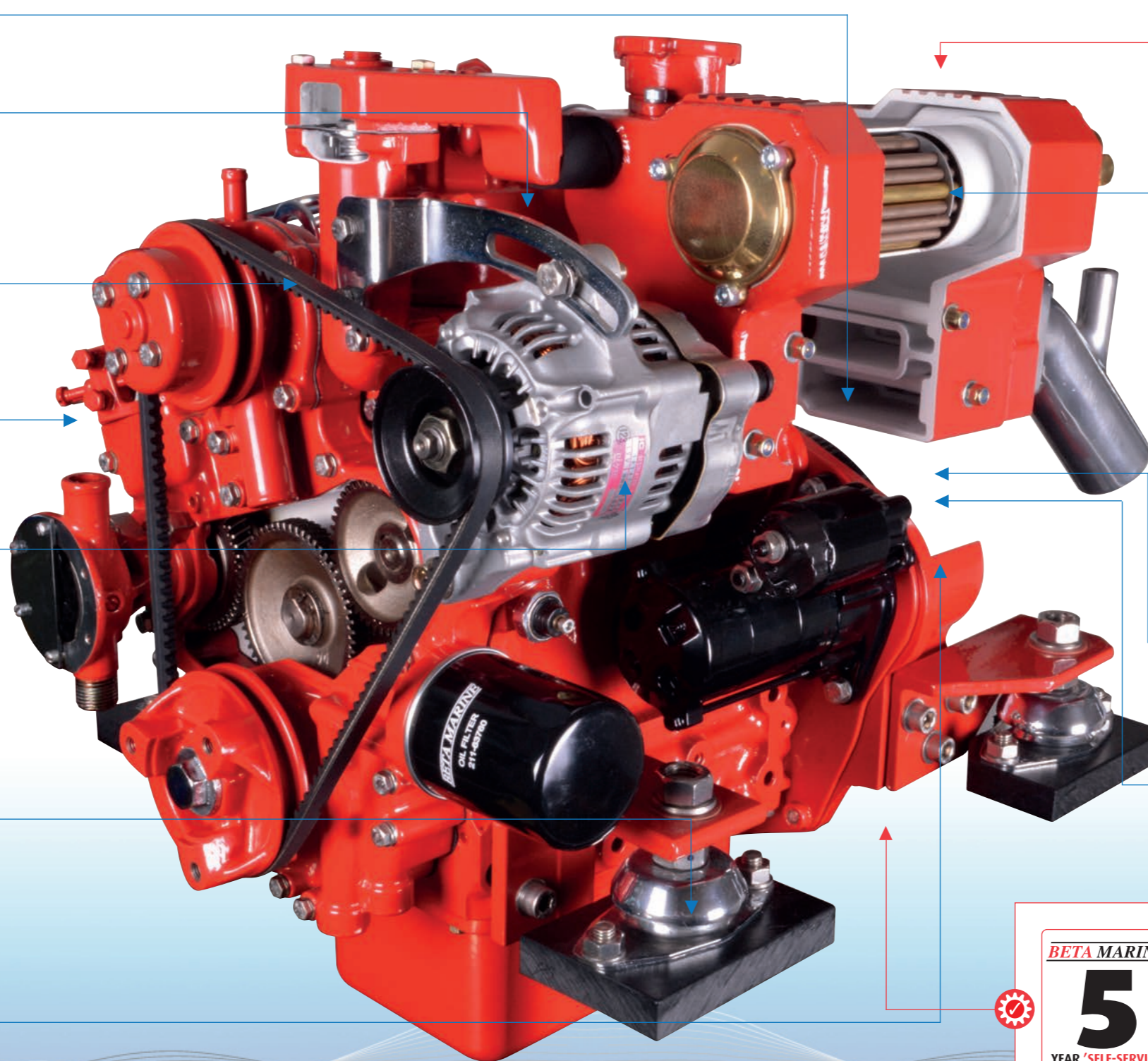

Complete with "ABV" Control Panel & 3m of interconnection cable, "Morse" type engine speed and gearbox control brackets & end fittings. Heavy duty feet and flexible mountings.

- **HEAT EXCHANGER COOLED**, the Beta 10, 14, 16, 20, 25, 30, 35 & 38 are naturally aspirated, whilst the Beta 45T is turbocharged.
- Three vortex combustion with indirect injection for quiet running, low emissions and excellent fuel consumption – Beta 10, 14, 16, 20, 25, 30, 35 & 38.
- ICVS combustion with direct injection for quiet running, low emissions and excellent fuel consumption – Beta 45T.

**BETA MARINE**  
**5**  
YEAR 'SELF-SERVICE' ENGINE WARRANTY

Subject to installation criteria & registration, Kubota based engine's used for recreational use benefit from a **5 YEAR 'SELF-SERVICE' ENGINE WARRANTY.**

# Beta 16

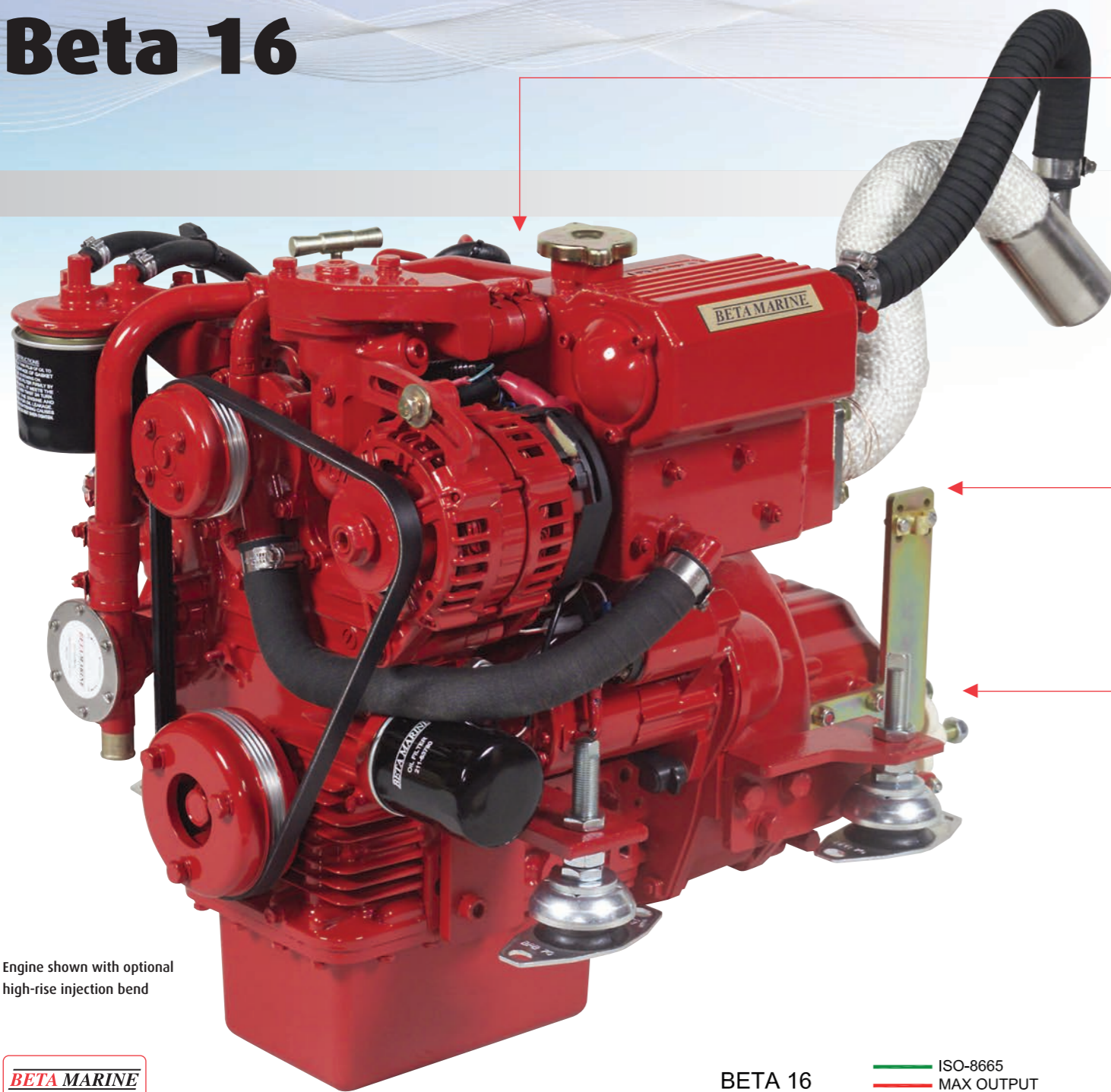

Engine shown with optional high-rise injection bend



Recreational use only

## Kubota Base Engine

	<b>Cylinders</b>	2
	<b>Displacement</b>	599cc
	<b>Power</b>	16hp max @ 3,600rpm
	<b>Weight</b>	95Kg
	<b>Propeller</b>	AIA*

A general guidance for propeller size in inches, based upon 3 blade RH rotation and reduction ratio of 2:1. \*For accurate individual advice please provide us with your vessels current full specifications

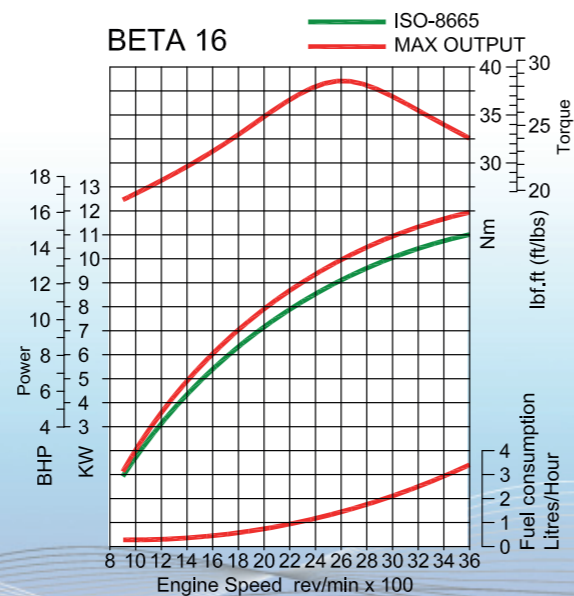

Based on theoretical propeller loading - matched at full speed

### Control Panel Options

A Panel	Opt.	C Deluxe Panel	Opt.
ABV Panel	Std.	CW Deluxe Panel	Opt.
ABVW Panel	Opt.	D Digital Panel	Opt.
B Panel	Opt.	Flybridge Control - Additional	
BW Panel	Opt.	C Panel & 6m Connection Cable	Opt.

### Electrical Options

40 Amp, 12 Volt Alternator	Std.	70 Amp, 12 Volt Insulated Return Alternator	Opt.
75 Amp, 12 Volt Alternator in Lieu of Standard	Opt.	125 Amp, 12 Volt Split Charging System	Opt.
120 Amp, 12 Volt Alternator in Lieu of Standard	Opt.		

### Gearbox Options

<b>Bobtail - No Gearbox</b>		<b>PRM Marine</b>	
"Bobtail" Engine with Drive Plate and Housing Only	Std.	PRM60 - Mechanical	Std.
<b>Technodrive / Twin Disc</b>		PRM90 - Mechanical	Opt.
TMC40 - Mechanical	Std.	PRM150 - Hydraulic	Opt.
TMC60 - Mechanical	Opt.	<b>ZF</b>	
TMC60A - 7° Down Angle, Mechanical	Std.	ZF15MIV - 15° V Drive, Mechanical	Std.

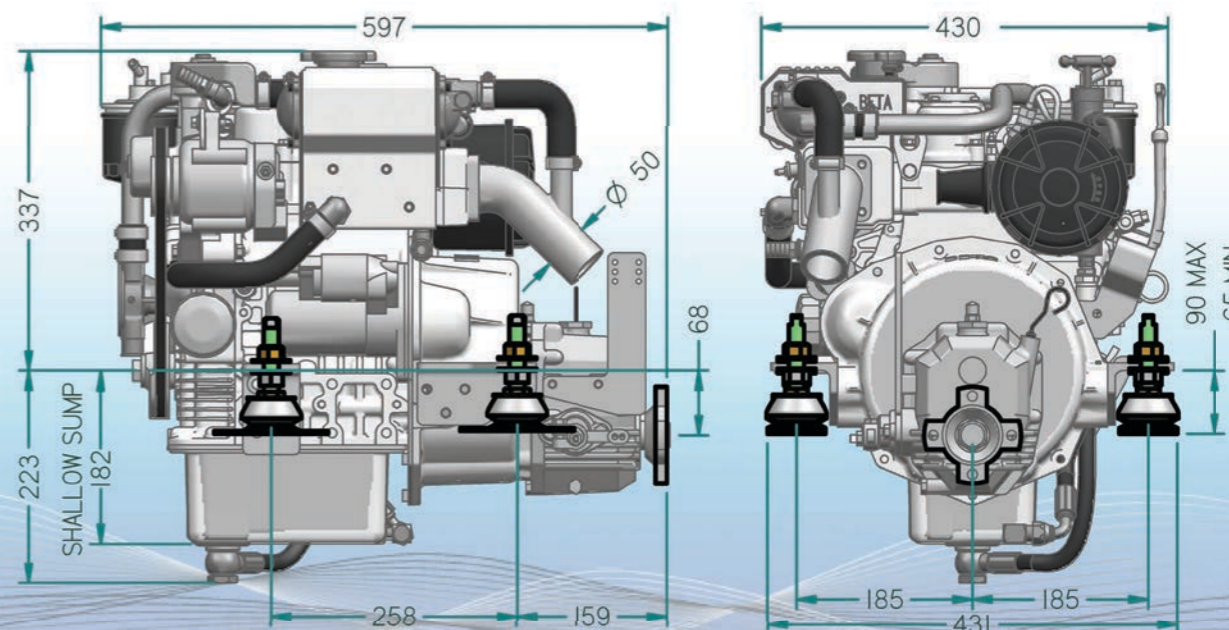

These are typical dimensions: visit our website for all engine / gearbox option drawings or contact Beta Marine direct